



**Catalogue**  
**CATERING**  
**Chapter**  
**OVENS**

**Model**  
 AG-202 NG 230V 1N 60Hz

19011928

24/01/2019

**GAS ADVANCE COMBI OVEN, AG-202**

High quality, fast cooking :

Professional quality  
 Easy to use and efficient  
 perfect results  
 Affordable

Capacity for 20 2/1-GN trays or 40 1/1-GN trays.

Stainless steel burner with electronic control system with sparking plug ignition.  
 Frequency modulation for the convection burner.  
 Push-button and "Scrolling" controls.  
 5 cooking methods: Steam, Low-temperature steam, Regeneration, Combination and Convection (up to 300°C).  
 Preheating option.  
 Overnight cooking or low-temperature programme.  
 3 Speeds - 2 power ranges.  
 Cold-Down chamber cooling system.  
 "Auto-reverse" system to reverse fan rotation.  
 Multisensor core temperature probe.  
 Steam generator equipped with limescale detector.  
 Steam generator automatically empties every 24 hours of cooking.  
 Semi-automatic limescale removal system.  
 Error detection system. "Repair service" mode system.  
 IPX-5 protection.  
 AUTOMATIC CLEANING - Wash program for the cooking chamber.  
 Retractable shower.  
 Includes trolley with integrated structure for trays CEB-202.

Accessories in option:

trolley with integrated Structure for dishes CEP-202  
 Thermal cover LTE-202

**DIMENSIONS**

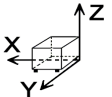

X Width	1162 mm	X Gross width	1250 mm
Y Depth	1074 mm	Y Gross depth	1200 mm
Z Height	1841 mm	Z Gross height	2080 mm
Net Weight	403,0 kg	Gross Weight	470,0 kg
Net volume	2,298 m3	Gross volume	3,120 m3

**ELECTRICITY TECHNICAL SPECIFICATIONS**

Electric power	2,400 kW
Voltage	230V - 1N
Amperage	10,4
Electric frequency	60Hz

**GAS TECHNICAL SPECIFICATIONS**

Gas type	NG
Gas power	65,00 kW
Regulated	NG G20/G25/G25.1 20/25/25 mbar

**WATER TECHNICAL SPECIFICATIONS**

Water max consumption	30,00 L/h
Pressure	H2O: 200-400kPa(2-4bar)

**OTHERS**

Noise level	62,00 dB
-------------	----------



Catalogue  
**CATERING**

Chapter  
**OVENS**

Model  
**AG-202 NG 230V 1N 60Hz**

19011928

24/01/2019

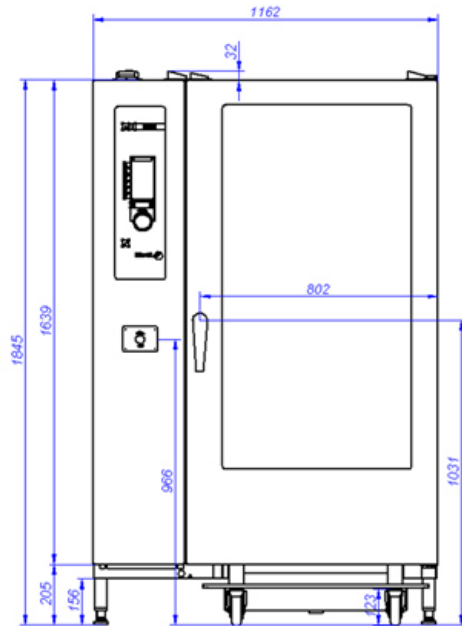

**AG-202**

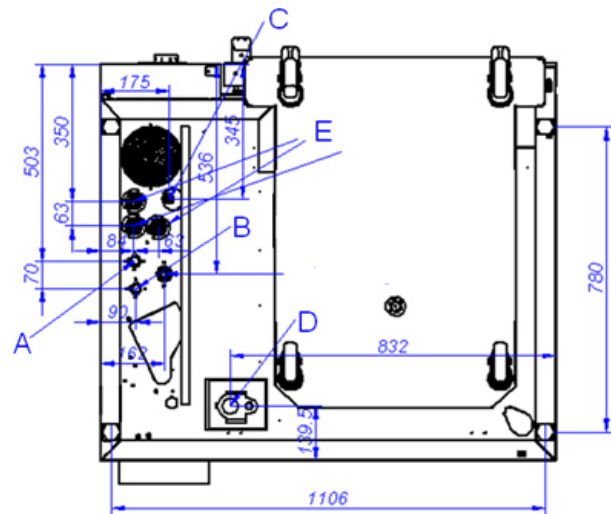

VISTA DE LA BASE DESDE LA PARTE INFERIOR  
VIEW FROM THE BOTTOM OF THE MACHINE

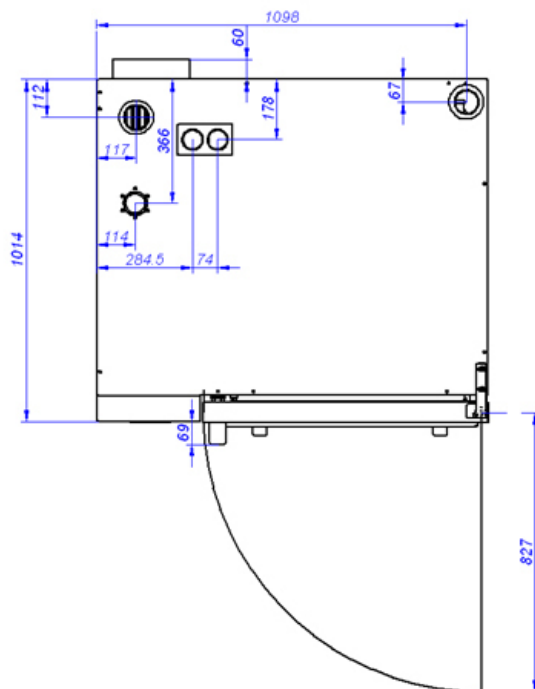

- A: Entrada de agua blanda
- B: Entrada de agua dura
- D: Desagüe

C: Alimentación eléctrica

E: Entrada de gas

F: Entrada de aire

- A: Soft water inlet
- B: Water inlet
- D: Drain

C: Electrical connection

E: Gas inlet

F: Air