



Catalogue
CATERING
Chapter
OVENS

Model
 AG-061 NG 230V 1N 60Hz

19011883

24/01/2019

GAS ADVANCE COMBI OVEN, AG-061

High quality, fast cooking :

Professional quality
 Easy to use and efficient
 perfect results
 Affordable

Capacity for 6 1/1-GN trays.

Stainless steel burner with electronic control system with sparking plug ignition.

Frequency modulation for the convection burner.

Push-button and "Scrolling" controls.

5 cooking methods: Steam, Low-temperature steam, Regeneration, Combination and Convection (up to 300°C).

Preheating option.

Overnight cooking or low-temperature programme.

3 Speeds - 2 power ranges.

Cold-Down chamber cooling system.

"Auto-reverse" system to reverse fan rotation.

Multisensor core temperature probe.

Steam generator equipped with limescale detector.

Steam generator automatically empties every 24 hours of cooking.

Semi-automatic limescale removal system.

Error detection system. "Repair service" mode system.

IPX-5 protection.

AUTOMATIC CLEANING - Wash program for the cooking chamber.

Retractable shower.

Accessories in option:

Support SH-11

Structure for trays EB-61

Structure for dishes EP-61

Loading trolley CP-11

DIMENSIONS

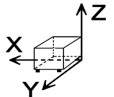

X Width	898 mm	X Gross width	980 mm
Y Depth	922 mm	Y Gross depth	1060 mm
Z Height	846 mm	Z Gross height	1100 mm
Net Weight	147,0 kg	Gross Weight	182,0 kg
Net volume	0,700 m3	Gross volume	1,143 m3

ELECTRICITY TECHNICAL SPECIFICATIONS

Electric power	1,200 kW
Voltage	230V - 1N
Amperage	5,2
Electric frequency	60Hz

GAS TECHNICAL SPECIFICATIONS

Gas type	NG
Gas power	12,00 kW
Regulated	NG G20/G25/G25.1 20/25/25 mbar

WATER TECHNICAL SPECIFICATIONS

Water max consumption	15,00 L/h
Pressure	H2O: 200-400kPa(2-4bar)

OTHERS

Noise level	62,00 dB
-------------	----------



Catalogue
CATERING

Chapter
OVENS

Model
AG-061 NG 230V 1N 60Hz

19011883

24/01/2019

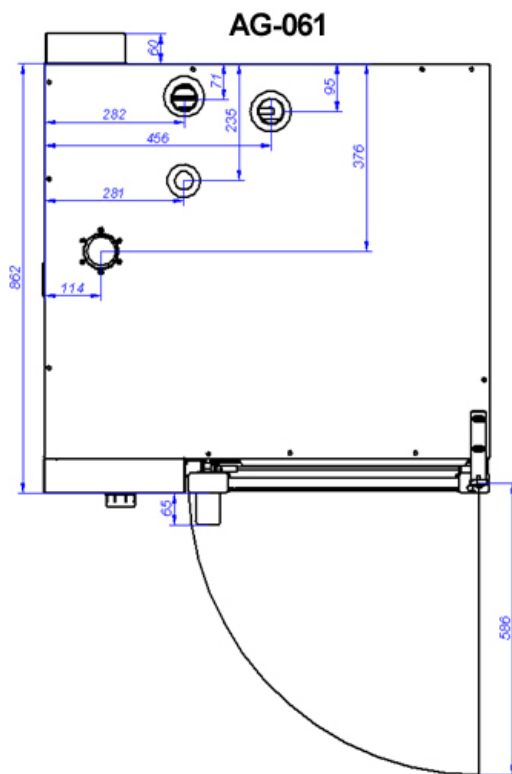
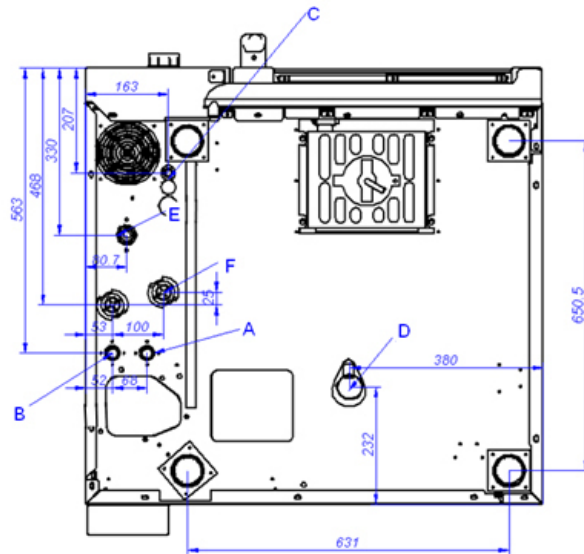
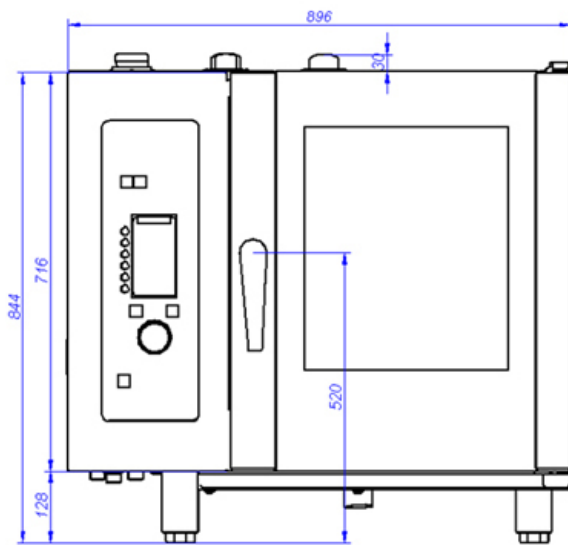

VISTA DE LA BASE DESDE LA PARTE INFERIOR
VIEW FROM THE BOTTOM OF THE MACHINE

A: Entrada de agua blanda
B: Entrada de agua dura
D: Desagüe

C: Alimentación eléctrica

E: Entrada de gas

F: Entrada de aire

A: Soft water inlet
B: Water inlet
D: Drain

C: Electrical connection

E: Gas inlet

F: Air