



Catalogue
CATERING
Chapter
DISHWASHING

Model
CCO-180 D ECO 380-415V 3N 60Hz

19048593

12/04/2019

CONVEYOR DISHWASHER CCO-180 D ECO

All the main parts are manufactured in AISI-304 anti-corrosion stainless steel: tanks, washing and rinsing arms, rinsing jets, doors, basket conveyance system, boiler and metal tubes.
Upwards-opening double panel door.
Tank tray filters made of AISI-304 stainless steel, easy to access and remove for cleaning and access to the tank.
Safety filter for pump suction.
Rinsing boiler with heat insulation.
Easy access for installation. Electrovalve located on one side (no need to remove panels to connect the machine).
Electrical panel designed for easy connection of dosers for liquid and solid detergents, rinse aid, limit switches, supplementary emergency stop button.
Washing arms easily removable as a set, for cleaning, with a plug on each branch providing access for cleaning inside.
Rinse jets easily dismountable and removable.
System of electronic regulation of speeds by means of frequency shifter.
Configurable electronic temperature control:
- Wash (50 - 65 °C)
- Rinse (70 - 85 °C)
Guarantor of rinse at 85 °C.
The ECO version pass-through dishwashers are fitted with an external hot water generator, gas heated, model GWB-40 (*).
The generator replaces the electric rinse boiler in the dishwasher, bringing a significant saving in electricity consumption.
Given the heating power of the generator, the dishwasher is for installation in facilities with a cold water connection.
The dishwasher has a motor pump to send the water from the generator to the rinse jets.
The dishwasher incorporates a flow regulator to ensure constant water consumption.
The first filling of the dishwasher wash tank takes place with water both from the generator and from the filling electrovalve.
Pressure regulator for flow control.
Emergency stop button incorporated.
Extra anti-entrapment protection system at the entrance, mounted on the AS-260 splash guard supplement, as standard.
Open door blocking system.
IPX4 protection system.
System for detection of blockage of conveyor carriage and automatic reverse function.
High-power washing system with 5 upper and 5 lower washing branches.
3 washing programs: intensive (DIN10534), medium and high-capacity.
Rinse and pre-rinse, both double effect.
Energy-saving system: reduces consumption by halting operation of the pumps, and by passing the heating of the rinse to stand-by mode (70 °C).
Auto-timer which deactivates the conveyor motor after a pre-set period of inactivity (10 minutes).
Energy saving system in the wash: the wash does not start up until it detects the passage of the basket.
Rinse saving system. The rinse stops which the basket has left, saving water and energy.
Model prepared for entrance of baskets from the right side.
Gas heating power: 48 kW.

Equipment included:
2 base baskets, CT-10
2 baskets for plates CP-16/18, 1 basket for

DIMENSIONS

X Width	1760 mm	X Gross width	1850 mm
Y Depth	790 mm	Y Gross depth	955 mm
Z Height	1560 mm	Z Gross height	1950 mm
Net Weight	259,0 kg	Gross Weight	382,0 kg
Net volume	2,529 m3	Gross volume	3,445 m3

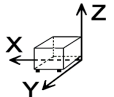

ELECTRICITY TECHNICAL SPECIFICATIONS

Electric power	19,900 kW
Heating power	17,00 kW
Voltage	380-415V - 3N
Amperage	32,9
Electric frequency	60Hz

WATER TECHNICAL SPECIFICATIONS

Pressure	H2O: 200-400kPa(2-4bar)
Water max consumption	210,00 L/h

CONNECTIONS TECHNICAL SPECIFICATIONS

230 V three-phase wiring	3X50+T - 160 A
Three-phase +N 40V wiring	4X6+T - 40 A
Hot diameter diameter	3/4"
Drain 1 diameter	38

OTHERS

Noise level	72,00 dB
-------------	----------



Catalogue
CATERING

Chapter
DISHWASHING

Model
CCO-180 D ECO 380-415V 3N 60Hz

19048593

12/04/2019

glasses CV-16/105, 1 basket for cutlery CT-10 R
Limit switch included.

Catalogue
CATERING
 Chapter
DISHWASHING

Model
CCO-180 D ECO 380-415V 3N 60Hz

19048593

12/04/2019

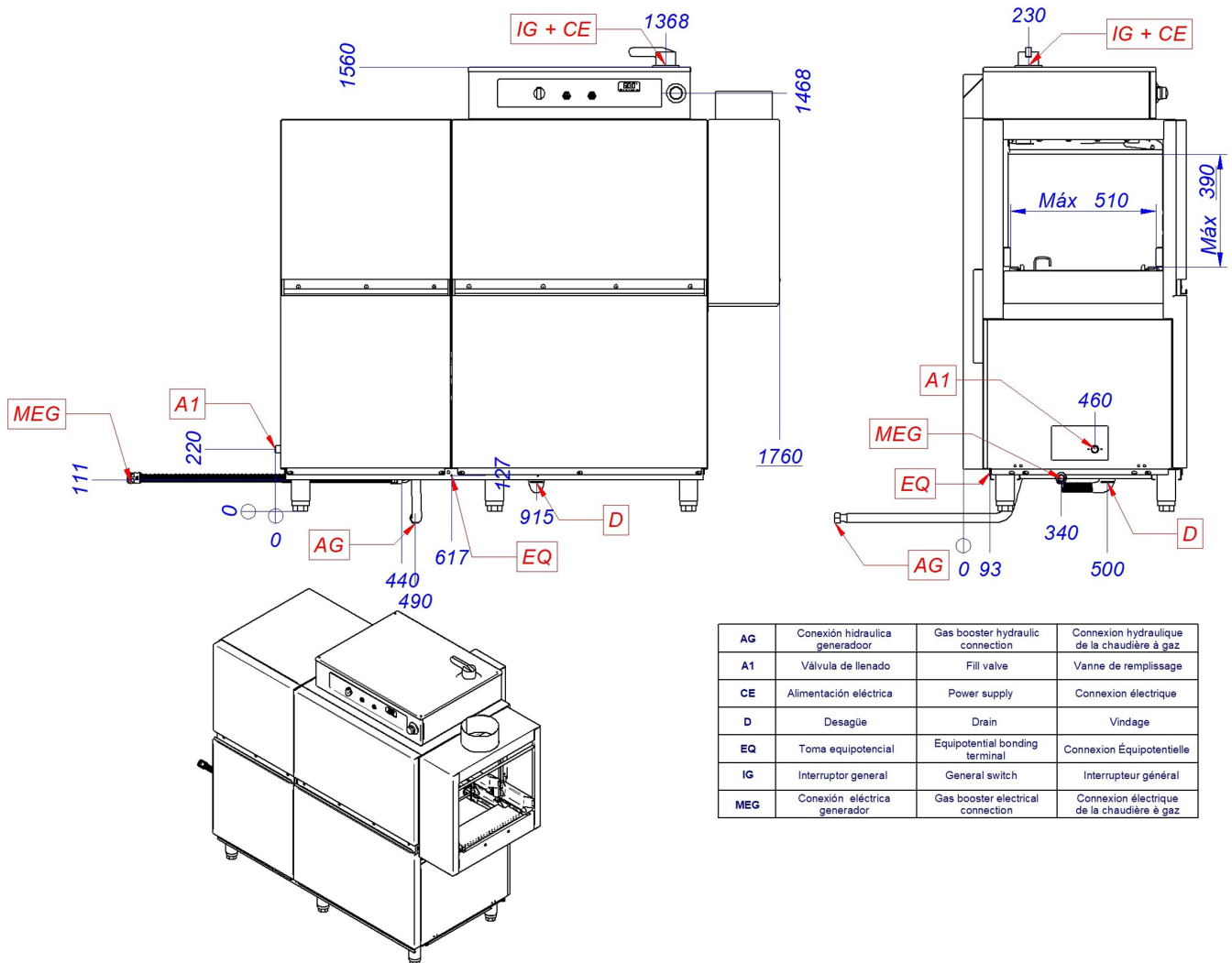

AG	Conexión hidráulica generador	Gas booster hydraulic connection	Connexion hydraulique de la chaudière à gaz
A1	Válvula de llenado	Fill valve	Vanne de remplissage
CE	Alimentación eléctrica	Power supply	Connexion électrique
D	Desagüe	Drain	Vindage
EQ	Toma equipotencial	Equipotential bonding terminal	Connexion Equipotentielle
IG	Interruptor general	General switch	Interrupteur général
MEG	Conexión eléctrica generador	Gas booster electrical connection	Connexion électrique de la chaudière à gaz